

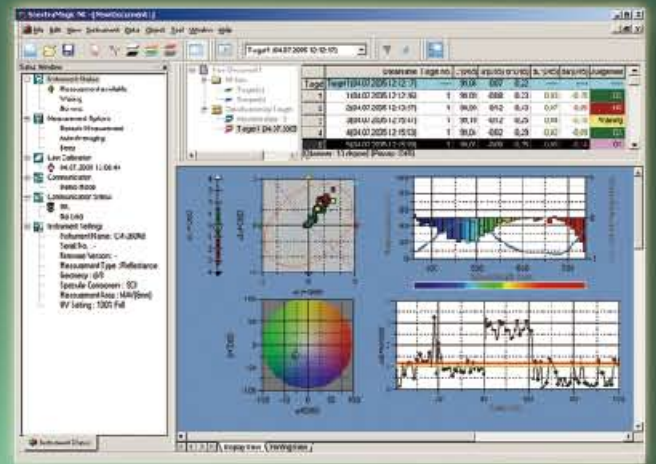

KONICA MINOLTA

# SPECTROPHOTOMETER CM-3700d



SpectraMagic™ **NX** (Optional)



The essentials of imaging

# A High-Accuracy Benchtop Spectrophotometer With Konica Minolta's Optical Technology for High Performance and Computer Control for Easy Operation

Demands for higher accuracy and more analysis capabilities have been increasing, particularly from R&D professionals. In response, Konica Minolta has utilized its long experience in optics and color measurement to create the Spectrophotometer CM-3700d, a high-accuracy benchtop spectrophotometer suitable for not only research and development, but also for quality control or CCM applications.

## High-speed, high-accuracy measurements

Measurements at wavelengths from 360 to 740nm at 10nm pitch are taken in approximately 0.6 seconds. Konica Minolta's optical technology ensures high absolute-value accuracy and repeatability, and extremely strict quality control provides higher inter-instrument agreement and reliability.

**1 Illumination/viewing geometry** meets ISO and DIN standards for di:8°, de:8° (diffuse illumination/8° viewing angle) geometry and also conforms to CIE and ASTM standards for d:0° (diffuse illumination/0° viewing angle) geometry.

**2 Pulsed xenon lamp light source** provides high stability, long life, and excellent repeatability on dark and high-chroma colors.

**3 6-inch integrating sphere** has a powdered barium sulfate (BaSO<sub>4</sub>) coating with superior optical characteristics.

**4 Double-beam feedback system** monitors the light emitted by the xenon lamp and automatically compensates for changes in brightness or spectral characteristics.

**5 Flat holographic grating** efficiently separates the light by wavelength to provide higher repeatability for dark colors.

**6 Silicon photodiode array sensor** quickly converts the light separated by the grating to electrical currents.

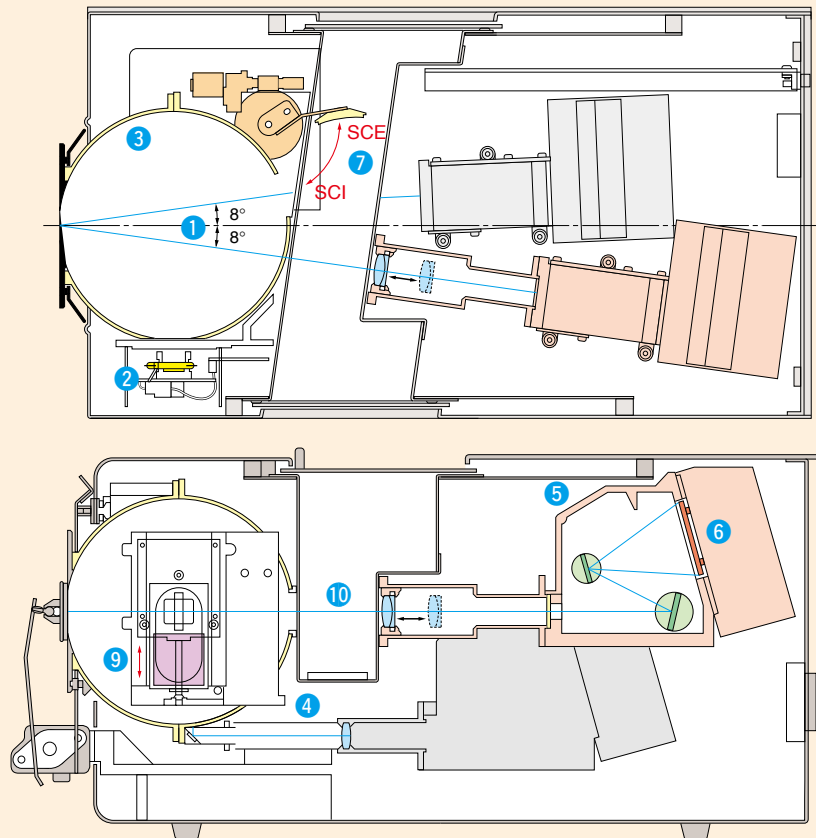

## Various measuring functions

### 7 Switchable between SCI and SCE measurements

SCI (specular component included) measurements minimize the influence of surface conditions on measured values, making it suitable for CCM applications. SCE (specular component excluded) measurements correspond closely to professional visual evaluation.

### 8 Changeable measurement areas

Select measurement areas of 3×5mm, ø8mm, or ø25.4mm according to the application.

### 9 Variable UV

The amount of UV included in the illumination can be controlled in 1000 steps for measurements of fluorescent materials.

### 10 Transmittance measurements

The spectral transmittance of liquids or of specimens in sheet or plate form can be measured using di:0°, de:0° (diffuse illumination/0° viewing angle) geometry.



# SpectraMagic™ **NX** (optional)

Supports Windows® 2000/XP/Vista

SpectraMagic™ **NX** enables you to perform comprehensive color inspection and analysis of incoming raw materials, in process production, and outbound color critical goods and materials in virtually any industry. With SpectraMagic™ **NX** you can insert digital images with measured data. Measure samples in any of 8 universally accepted color spaces. Select from 15 illuminants, and up to 40 indices to determine specific color and appearance properties, such as strength, brightness, haze, yellowness, opacity and strength. You can even configure up to 3 customized color equations. Reports range from simple Pass/Fail to trend charts, histograms, color plots, and spectral graphs. SpectraMagic™ **NX** comes with predefined templates using skin technology, or you can create your own templates. For illustrations and explanations to understanding color and color measurement technology, there is a link to Konica Minolta's well known and respected "Precise Color Communication". Step by step navigation help.

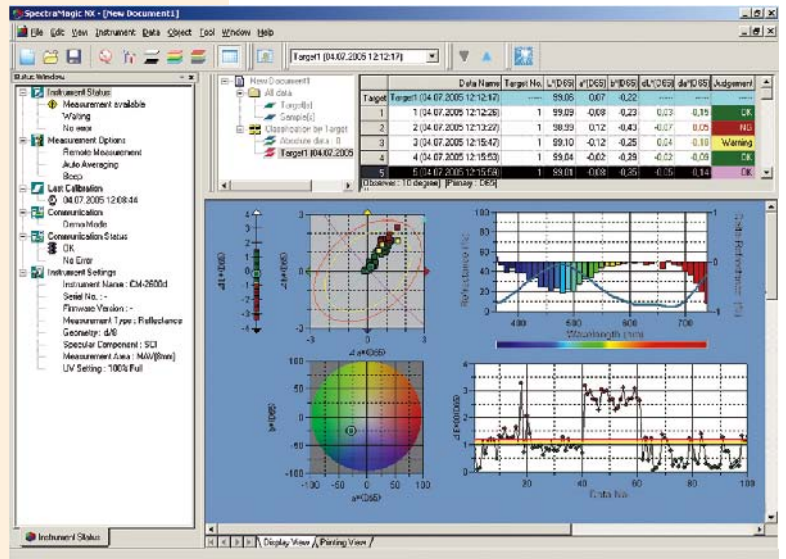

★ Windows® is a trademark of Microsoft Corporation in the USA and other countries.

## System Diagram

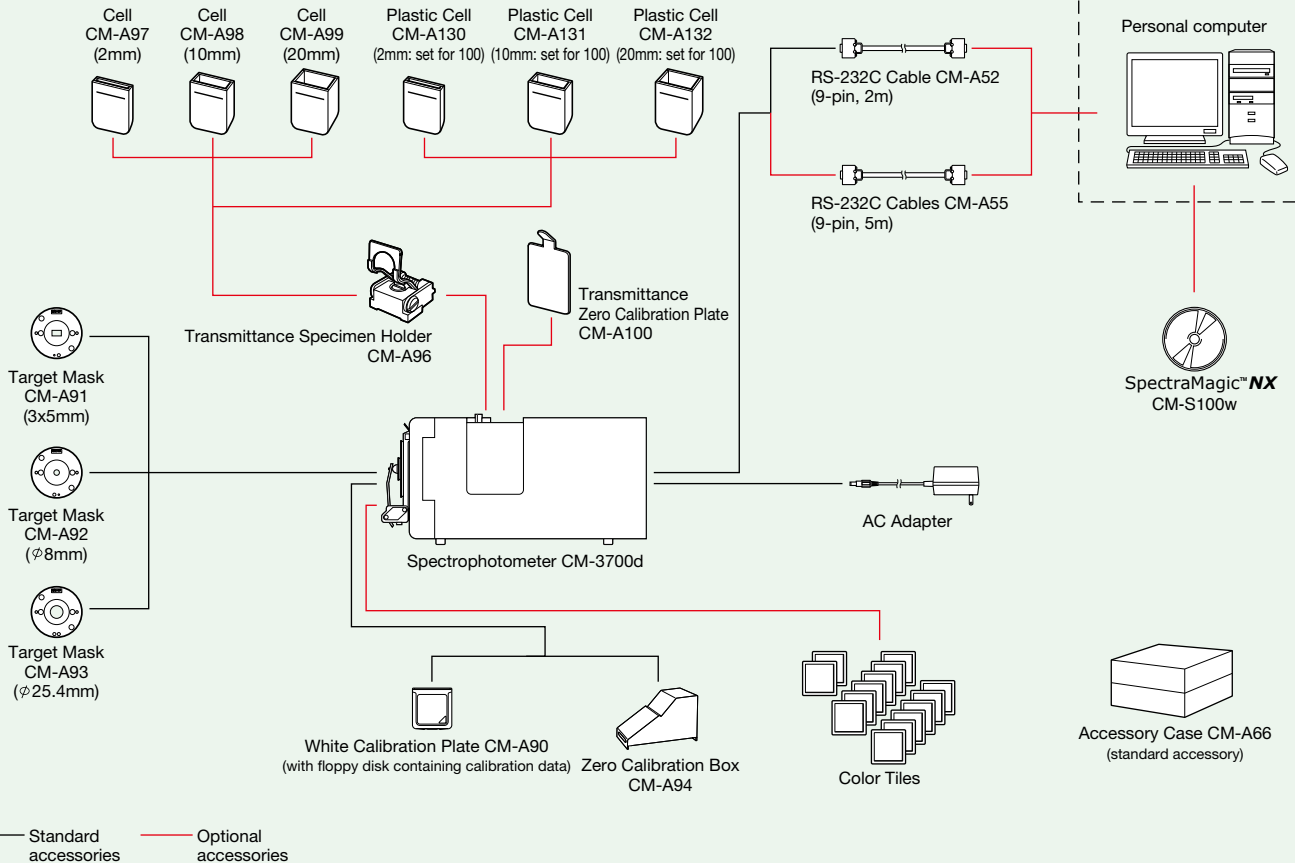

# Optional Accessories

## Transmittance Specimen Holder CM-A96

Holds specimens in place for transmittance measurements. Maximum specimen thickness: 22.5mm



## Glass Cell CM-A97/CM-A98/CM-A99

Hold liquid specimens for transmittance measurements. Optical path lengths: 2mm (CM-A97), 10mm (CM-A98), and 20mm (CM-A99)



Plastic Cells CM-A130(2mm), CM-A131(10mm), CM-A132(20mm) are also available.

## Transmittance Zero Calibration Plate CM-A100

For performing zero calibration for transmittance measurements.



## Color Tiles

14 color tiles are available: White, Pale grey, Middle grey, Difference grey, Deep grey, Deep pink, Red, Orange, Bright yellow, Green, Difference green, Cyan, Deep blue, Black. Original materials of these tiles are supplied by BCRA.



## Specifications (CM-3700d)

<b>Measuring geometry</b>	Reflectance: di:8 , de:8 (diffuse illumination/8 viewing angle); SCI (specular component included) /SCE(specular component excluded) switchable; meets CIE, ISO, ASTM, and DIN standards. Transmittance: di:0 , de:0 (diffuse illumination/0 viewing angle)
<b>Detector</b>	Silicon photodiode array with flat holographic grating
<b>Wavelength range</b>	360 to 740nm
<b>Wavelength pitch</b>	10nm
<b>Half bandwidth</b>	Approx. 14nm average
<b>Photometric range</b>	0 to 200%; Resolution: 0.001%
<b>Light source</b>	Pulsed xenon arc lamp
<b>Measurement time</b>	0.6 to 0.8 sec. (to start of data output)
<b>Illumination/ measurement areas</b>	Reflectance: Changeable between LAV, MAV, and SAV LAV: ø28mm illumination/ø25.4mm measurement MAV: ø11mm illumination/ø8mm measurement SAV: 5x7mm illumination/3x5mm measurement Transmittance: Approx. ø20mm
<b>Repeatability</b>	When white calibration plate is measured 30 times at 10-sec. intervals after white calibration has been performed: Spectral reflectance: Standard deviation within 0.05% Chromaticity: Standard deviation within ΔE*ab0.005 When black tile(BCRA Series II ; reflectance: 1%)is measured 30 times at 10-second intervals after white calibration has been performed: Spectral reflectance: 380 to 740nm: Standard deviation within 0.02% 360 and 370nm: Standard deviation within 0.04% Chromaticity: Standard deviation within ΔE*ab0.05
<b>Inter-instrument agreement</b>	mean ΔE*ab0.08 (typical) Average for 12 BCRA Series II color tiles. Max ΔE*ab0.3(corresponds to approx. ΔE*cmc 0.2) for any of 12 BCRA Series II color tiles compared to values measured with master body ; LAV.
<b>Temperature drift</b>	Spectral reflectance: Within ±0.10%/ C, Color difference: Within ±ΔE*ab0.05/ C
<b>UV adjustment</b>	Computer controlled: continuously variable
<b>Specimen conditions for transmittance measurements</b>	Sheet, plate, or liquid form up to a maximum thickness of approximately 50mm
<b>Interface</b>	RS-232C standard; baud rates: 1200,2400,4800,or 9600
<b>Power</b>	AC 100V/120V/230V 50/60Hz (using included AC adapter)
<b>Operation temperature/humidity range (*1)</b>	13 to 33 C, relative humidity 80% or less with no condensation
<b>Storage temperature/humidity range</b>	0 to 40 C, relative humidity 80% or less with no condensation
<b>Dimensions (W×H×D)</b>	271 × 259 × 500mm(10-11/16 × 10-3/16 × 19-11/16 in.)
<b>Weight</b>	18kg(39.7 lb.)
<b>Standard accessories</b>	White Calibration Plate; Target Mask(3×5mm); Target Mask(ø8mm); Target Mask(ø25.4mm); Zero Calibration Box; AC Adapter; RS-232C Cable(9-pin, 2m); Accessory Case CM-A66
<b>Optional accessories</b>	Transmittance Specimen Holder; Glass Cells(2mm, 10mm, 20mm); Plastic Cells(2mm, 10mm, 20mm); Transmittance Zero Calibration Plate; Color Tiles; RS-232C Cable(9-pin, 5m)

\*1 Operating temperature/humidity range of products for North America : 13 to 33 C, relative humidity 80% or less (at 31 C) with no condensation

## Dimensions (Units:mm)

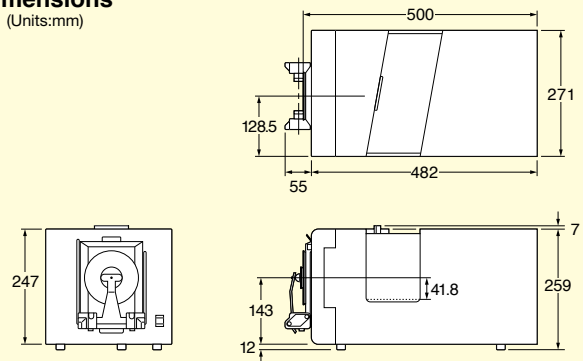

●Specifications are subject to change without notice.



Certificate No : YKA 0937154  
Registration Date : March 3, 1995



Certificate No : JQA-E-80027  
Registration Date : March 12, 1997

## SAFETY PRECAUTIONS



For correct use and for your safety, be sure to read the instruction manual before using the instrument.

● Always connect the instrument to the specified power supply voltage. Improper connection may cause a fire or electric shock.

**KONICA MINOLTA SENSING, INC.**  
Konica Minolta Sensing Americas, Inc  
Konica Minolta Sensing Europe B.V.

Osaka, Japan  
New Jersey, U.S.A.  
European Headquarter /BENELUX  
German Office  
French Office  
UK Office  
Italian Office  
Belgian Office  
Swiss Office  
Nordic Office  
Austrian Office  
Polish Office

**Konica Minolta (CHINA) Investment Ltd.**  
SE Sales Division  
Beijing Branch  
Guangzhou Branch  
Chongqing Office

**Konica Minolta Sensing Singapore Pte Ltd.**

**KONICA MINOLTA SENSING, INC.**

Seoul Office

**Phone** : 888-473-2656(in USA), 201-236-4300(outside USA)

Nieuwegein, Netherland  
München, Germany  
Roissy CDG, France  
Milton Keynes, United Kingdom  
Milan, Italy  
Zaventem, Belgium  
Dietikon, Switzerland  
Västra Frölunda, Sweden  
Wien, Austria  
Wroclaw, Poland

Shanghai, China  
Beijing, China  
Guangzhou, China  
Chongqing, China  
Singapore  
Seoul, Korea

**Phone** : +31(0)30 248-1193  
**Phone** : +49(0)89 4357 156 0  
**Phone** : +33(0)1 493-82519  
**Phone** : +44(0)1908 540-622  
**Phone** : +39 02 39011.425  
**Phone** : +32 (0)2 7170 933  
**Phone** : +41(0)43 322-9800  
**Phone** : +46(0)31 7099464  
**Phone** : +43(0)1 87882-430  
**Phone** : +48(0)71 33050-01  
**Phone** : +86-021-5489 0202  
**Phone** : +86-010-8522 1551  
**Phone** : +86-020-3826 4220  
**Phone** : +86-023-6773 4988  
**Phone** : +65 6563-5533  
**Phone** : +82(0)2-523-9726

**Fax** : 201-785-2482

**Fax** : +31(0)30 248-1280  
**Fax** : +49(0)89 4357 156 99  
**Fax** : +33(0)1 493-84771  
**Fax** : +44(0)1908 540-629  
**Fax** : +39 02 39011.223  
**Fax** : +32 (0)2 7170 977  
**Fax** : +41(0)43 322-9809  
**Fax** : +46(0)31 474945  
**Fax** : +43(0)1 87882-431  
**Fax** : +48(0)71 734 52 10  
**Fax** : +86-021-5489 0005  
**Fax** : +86-010-8522 1241  
**Fax** : +86-020-3826 4223  
**Fax** : +86-023-6773 4799  
**Fax** : +65 6560-9721  
**Fax** : +82(0)2-523-9729

Addresses and telephone/fax numbers are subject to change without notice. For the latest contact information, please refer to the KONICA MINOLTA SENSING Worldwide Offices web page :

<http://konicaminolta.com/instruments/about/network>